

# FREEDOM PACKAGE 1

AHR75 + AFC001AC + AHR150A-2A



Legacy Vertical Gyro (VG) and Directional Gyro (DG) systems are facing increasing obsolescence, resulting in costly repairs, reduced reliability, and extended downtime. Recognizing the need for a modern replacement solution Archangel Systems has developed two convenient packages - **Freedom 1** and **Freedom 2** – each targeted at a specific avionics configuration.

**Freedom 1** supports aircraft that have an existing, viable digital Air Data system. The AHR75 AHRS interfaces to this Air Data System as well as to our AHR150A-2A Magnetometer & AFC001AC digital to analog converter. The AFC in turn provides 2 and 3 wire synchro outputs to devices such as electromechanical Flight Directors, HSI's,

## FEATURES OF FREEDOM 1

Dedicated adapter harness & mounting plates simplify installation.

Smaller & lighter than existing VG/DG.

Greatly increased MTBF compared to the existing Gyros

Mounts on most previous DGWVG locations, no structural mods required.

Minor AOG time, less labor hours and reduced installation issues

Option to add more A429 devices in the future (Cockpit modernization)

## FREEDOM 1 PACKAGE CONTENT:

- AHR75
- AFC001AC
- AHR150A-2A MSU
- Mounting Plates FX004-XX and FX005-XX
- CA001-XX Cable and connectors

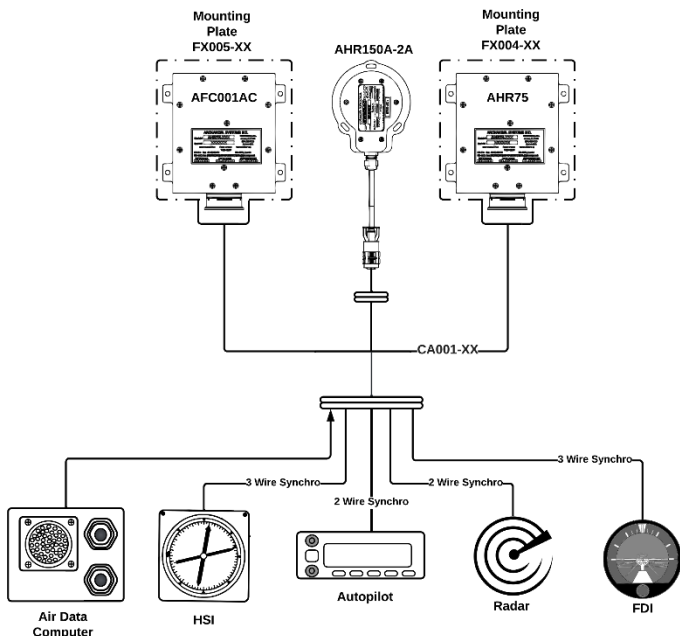

AHR75 & AHR150A-2A MSU

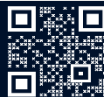

# FREEDOM PACKAGE 2

## AHR150A + AFC001AC + AHR150A-2



In addition to providing a solution for Vertical Gyro (VG) and Directional Gyro (DG) replacement, **Freedom 2** was developed to upgrade aircraft with legacy analog Air Data Systems. Consisting of our AHR150A ADAHRS, the system can provide Air Data, Heading and Attitude. It also includes our **AFC001AC** digital to analog converter. As in **Freedom 1**, the latter provides 2 and 3 wire synchro outputs for interface to existing analog devices.

The Air Data functionality of the AHR150A ADAHRS is RVSM capable and can accept Static Source Error Corrections. This configuration supports future digital avionics connected to the ADAHRS via its Hi and Low speed ARINC 429 busses. This provides not only a solution for the DGVG obsolescence but also a first step towards the upgrade of Legacy cockpits to a digital modern Flight Deck.

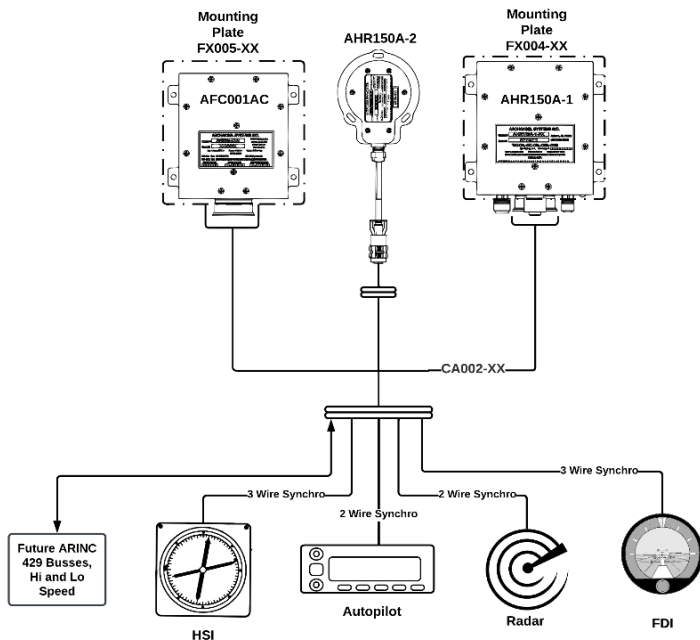

### FEATURES OF FREEDOM 2

Dedicated adapter harness & mounting plates simplify installation.

Smaller & lighter than existing VG/DG.

Provides an economical RVSM capable digital Air Data solution.

Mounts on most previous DGVG locations, no structural mods required.

Entire system provides an increased MTBF, resulting in reduced downtime.

Option to add more A429 devices in the future (Cockpit modernization)

### FREEDOM PACKAGE 2 CONTENT:

- AHR150A-1
- AHR150A-2 MSU
- AFC001AC
- Mounting Plates FX004-XX and FX005-XX
- CA001-XX Cable and connectors

